

По вопросам продаж и поддержки обращайтесь:

Архангельск (8182)63-90-72	Краснодар (861)203-40-90	Санкт-Петербург (812)309-46-40
Астана (7172)727-132	Красноярск (391)204-63-61	Саратов (845)249-38-78
Астрахань (8512)99-46-04	Курск (4712)77-13-04	Севастополь (8692)22-31-93
Барнаул (3852)73-04-60	Липецк (4742)52-20-81	Симферополь (3652)67-13-56
Белгород (4722)40-23-64	Магнитогорск (3519)55-03-13	Смоленск (4812)29-41-54
Брянск (4832)59-03-52	Москва (495)268-04-70	Сочи (862)225-72-31
Владивосток (423)249-28-31	Мурманск (8152)59-64-93	Ставрополь (8652)20-65-13
Волгоград (844)278-03-48	Набережные Челны (8552)20-53-41	Сургут (3462)77-98-35
Вологда (8172)26-41-59	Нижний Новгород (831)429-08-12	Тверь (4822)63-31-35
Воронеж (473)204-51-73	Новокузнецк (3843)20-46-81	Томск (3822)98-41-53
Екатеринбург (343)384-55-89	Новосибирск (383)227-86-73	Тула (4872)74-02-29
Иваново (4932)77-34-06	Омск (3812)21-46-40	Тюмень (3452)66-21-18
Ижевск (3412)26-03-58	Орел (4862)44-53-42	Ульяновск (8422)24-23-59
Казань (843)206-01-48	Оренбург (3532)37-68-04	Уфа (347)229-48-12
Калининград (4012)72-03-81	Пенза (8412)22-31-16	Хабаровск (4212)92-98-04
Калуга (4842)92-23-67	Пермь (342)205-81-47	Челябинск (351)202-03-61
Кемерово (3842)65-04-62	Ростов-на-Дону (863)308-18-15	Череповец (8202)49-02-64
Киров (8332)68-02-04	Рязань (4912)46-61-64	Ярославль (4852)69-52-93
	Самара (846)206-03-16	

Единый адрес: snw@nt-rt.ru **Веб-сайт:** www.swan.nt-rt.ru

Анализаторы AMI Phosphate II SWAN. Техническое описание

Complete monitoring system for the automatic, continuous measurement of phosphate in potable water, effluents and cooling water.

Monitor AMI Phosphate-II

- Measuring range: 0.01 to 10 ppm (mg/L) PO₄
- Based on colorimetric measurement principle according to EN ISO 6878 / APHA 4500 –P E.
- No interferences with silica.
- Complete system including measurement and control electronics, photometer, flow indicator, reaction chamber, reagent dosing system and reagent containers.
- Measurement values are available as analog output signals.
- Alarm display and activation of alarm relay when user defined, critical limits are reached.
- Continuous, automatic monitoring of main instrument functions (sample flow, reagent supply).
- Large back-lit LC display showing all measured values and status information simultaneously.
- Easy user menus in English, German, French and Spanish. Simple programming of all parameters by keypad.
- Data logger for 1'500 data records stored at a selectable interval. (Data download requires optional HyperTerminal interface).
- Factory tested, ready for installation and operation.

Accessories

- *Cleaning Module* for automatic chemical cleaning of flow cell and photometer. For details see separate data sheet no. DenA82312000.

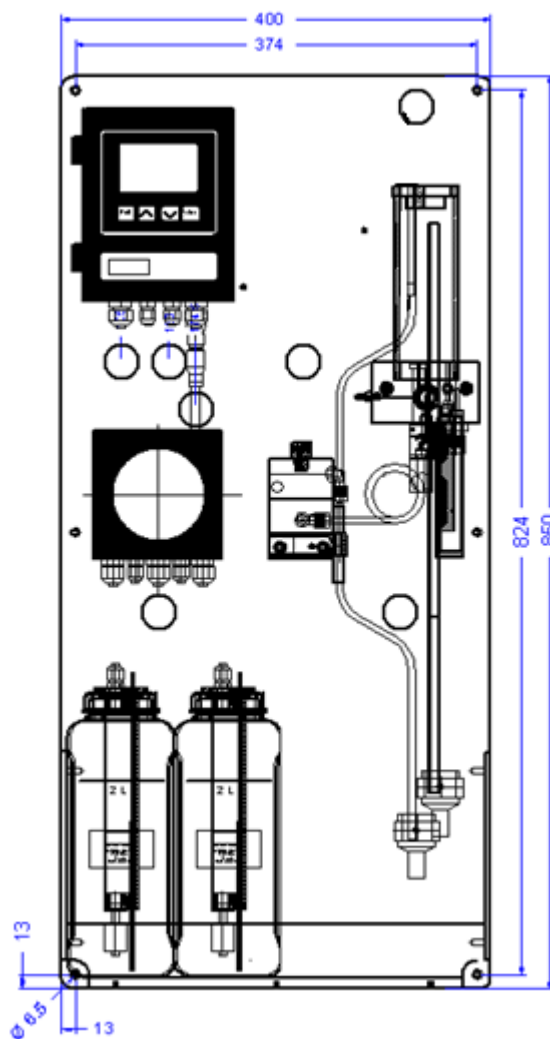

Monitor AMI Phosphate-II

Order scheme	Monitor AMI Phosphate-II	A-25.421.100
Option 1:	<input type="checkbox"/> 3 rd current signal output (0/4 – 20mA)	A-81.420.050
	<input type="checkbox"/> Profibus DP & Modbus RTU interface (RS-485)	A-81.420.020
	<input type="checkbox"/> USB interface	A-81.420.042

Analytical System

Phosphate (PO₄) measurement

Measuring range: Resolution
 0.01 to 0.99 ppm 0.01 ppm
 1.0 to 4.9 ppm 0.1 ppm
 5 to 10 ppm 1.0 ppm
 Reproducibility:
 up to 5 ppm ± 0.01 ppm or ± 2.5%,
 whichever is the greater
 5 to 10 ppm ± 10%
 Measurement time: 7 minutes
 Cycle time: 10 minutes

Flow cell

Made of acrylic glass with water inlet filter and flow adjustment valve.

Transmitter Specifications and Functionality

Electronics case: Aluminum
 Protection degree: IP 66 / NEMA 4X
 Display: backlit LCD, 75 x 45 mm
 Electrical connectors: screw clamps
 Ambient temperature: -10 to +50 °C
 Limit range of operation: -25 to +65 °C
 Storage and transport: -30 to +85 °C
 Humidity: 10 to 90 % relative,
 non condensing

Power supply

Voltage: 100 - 240 VAC (± 10 %),
 50/60 Hz (± 5 %)
 or 24 VDC (± 10 %)
 Power consumption: max. 30 VA

Operation

Easy operation based on separate menus for "Messages", "Diagnostics", "Maintenance", "Operation" and "Installation".

Separate menu specific password protection possible.

Display of process value, sample flow, alarm status and time during operation.

Storage of event log, alarm log and calibration history.

Storage of the last 1'500 data records in logger with selectable interval.

Real-time clock with calendar

For action time stamp and pre-programmed actions.

Safety features

Data storage in non-volatile memory.
 Over voltage protection of in- and outputs.
 Galvanic separation of measuring inputs and signal outputs.

Reagents monitoring

Warning if low level is reached and alarm for lack of reagents.

Temperature monitoring

Alarm if the transmitter temperature is higher than +65 °C or lower than 0 °C.

1 Alarm relay

One potential free contact for summary alarm indication for programmable alarm values and instrument faults.
 Maximum load: 1A / 250 VAC

Electrical Connection Scheme

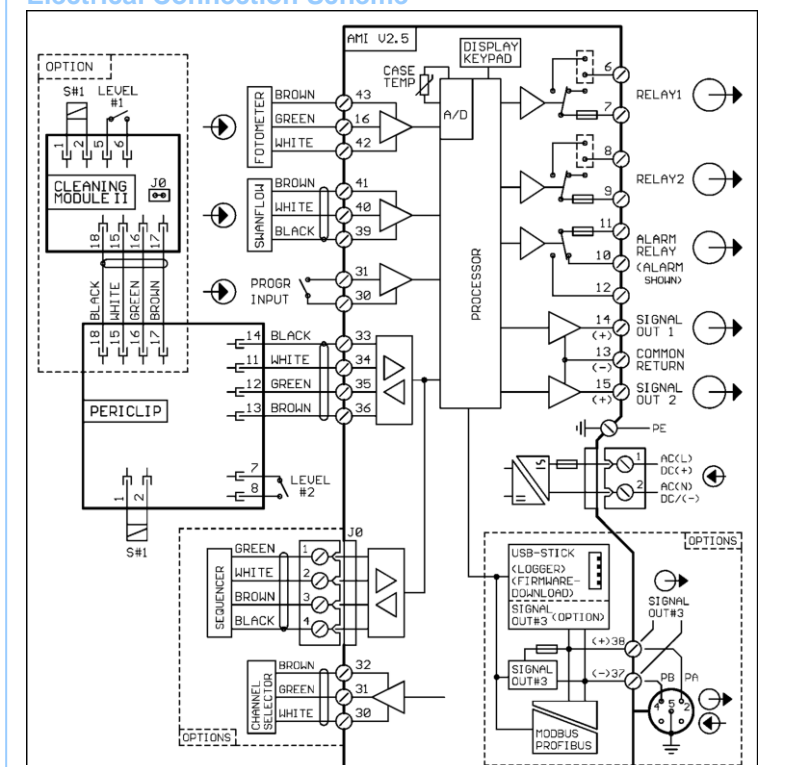

1 Input

One input for potential-free contact. Programmable hold or remote off function

2 Relay outputs

Two potential-free contacts programmable as limit switches for measuring values, controllers or timer with automatic hold function.
 Max. load: 1A / 250 VAC

2 Signal outputs (3rd as option)

Two programmable signal outputs for measured values (freely scalable, linear or bilinear) or as continuous control output (control parameters programmable) as current source. 3rd signal output selectable as current source or current sink.
 Current loop: 0/4 - 20 mA
 Maximum burden: 510 Ω

Control function

Relays or current outputs programmable for 1 or 2 pulse dosing pumps, solenoid valves or for one motor valve. Programmable P, PI, PID or PD control parameters.

1 Communication interface (option)

- RS485 interface (galvanically separated) with Fieldbus protocol Modbus RTU or Profibus DP
- 3rd Signal output
- USB interface

Sample and Monitor Data

Sample conditions

Flow rate: min. approx. 10 l/h
 Temperature: up to 50 °C
 Inlet pressure: 0.15 to 2 bar
 Outlet pressure: pressure free, atmospheric drain

Sample connections

Inlet: Serto PVDF 8 mm (1/4"), for tubing tubing 6x8 mm
 Drain: Ø 16 mm, tubing 15x20 mm

Panel

Dimensions: 400 x 850 x 200 mm
 Material: white PVC
 Weight: 9.5 kg

По вопросам продаж и поддержки обращайтесь:

Архангельск (8182)63-90-72

Астана (7172)727-132

Астрахань (8512)99-46-04

Барнаул (3852)73-04-60

Белгород (4722)40-23-64

Брянск (4832)59-03-52

Владивосток (423)249-28-31

Волгоград (844)278-03-48

Вологда (8172)26-41-59

Воронеж (473)204-51-73

Екатеринбург (343)384-55-89

Иваново (4932)77-34-06

Ижевск (3412)26-03-58

Казань (843)206-01-48

Калининград (4012)72-03-81

Калуга (4842)92-23-67

Кемерово (3842)65-04-62

Киров (8332)68-02-04

Краснодар (861)203-40-90

Красноярск (391)204-63-61

Курск (4712)77-13-04

Липецк (4742)52-20-81

Магнитогорск (3519)55-03-13

Москва (495)268-04-70

Мурманск (8152)59-64-93

Набережные Челны (8552)20-53-41

Нижний Новгород (831)429-08-12

Новокузнецк (3843)20-46-81

Новосибирск (383)227-86-73

Омск (3812)21-46-04

Орел (4862)44-53-42

Оренбург (3532)37-68-04

Пенза (8412)22-31-16

Пермь (342)205-81-47

Ростов-на-Дону (863)308-18-15

Рязань (4912)46-61-64

Самара (846)206-03-16

Санкт-Петербург (812)309-46-40

Саратов (845)249-38-78

Севастополь (8692)22-31-93

Симферополь (3652)67-13-56

Смоленск (4812)29-41-54

Сочи (862)225-72-31

Ставрополь (8652)20-65-13

Сургут (3462)77-98-35

Тверь (4822)63-31-35

Томск (3822)98-41-53

Тула (4872)74-02-29

Тюмень (3452)66-21-18

Ульяновск (8422)24-23-59

Уфа (347)229-48-12

Хабаровск (4212)92-98-04

Челябинск (351)202-03-61

Череповец (8202)49-02-64

Ярославль (4852)69-52-93

Единый адрес: snw@nt-rt.ru **Веб-сайт:** www.swan.nt-rt.ru